

FPL

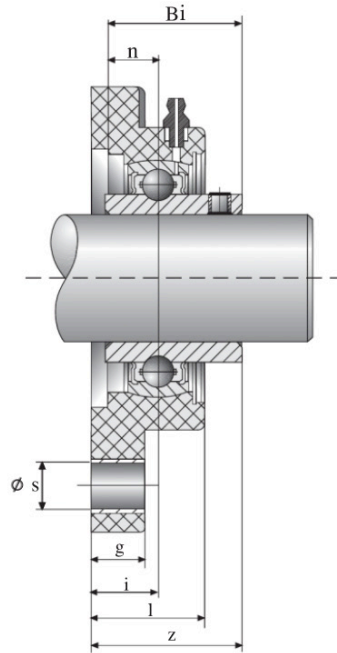
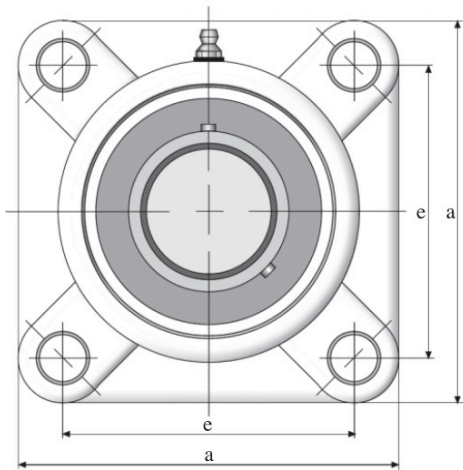

Housing Number	Shaft diameter Mm	Dimensions (mm)									Weight (kg)	max. TORQUE	
		a	e	g	l	s	z	i	Bi	n		bolt d.	Nm
FPL201	12	87	63,5	13,4	27,8	11	36,3	18	31	12,7	0,32	M10	18
FPL202	15	87	63,5	13,4	27,8	11	36,3	18	31	12,7	0,31	M10	18
FPL203	17	87	63,5	13,4	27,8	11	36,3	18	31	12,7	0,30	M10	18
FPL204	20	87	63,5	13,4	27,8	11	36,3	18	31	12,7	0,29	M10	18
FPL205	25	95	70	14,3	28	11	36,7	17	34	14,3	0,36	M10	25
FPL206	30	107	83	14,3	31,5	11	41,4	19,2	38,1	15,9	0,50	M10	30
FPL207	35	118	92	15,5	34,8	13	46,9	21,5	42,9	17,5	0,74	M12	35
FPL208	40	130	102	17	37,5	14	53,2	23	49,2	19	0,97	M12	40
FPL209	45	137	105	19	41	17	54,2	24	49,2	19	1,10	M16	45
FPL210	50	143	111	21	43	17	57,2	25	51,6	19	1,25	M16	50