

biplanar thermoplastic chains

1500 SERIES

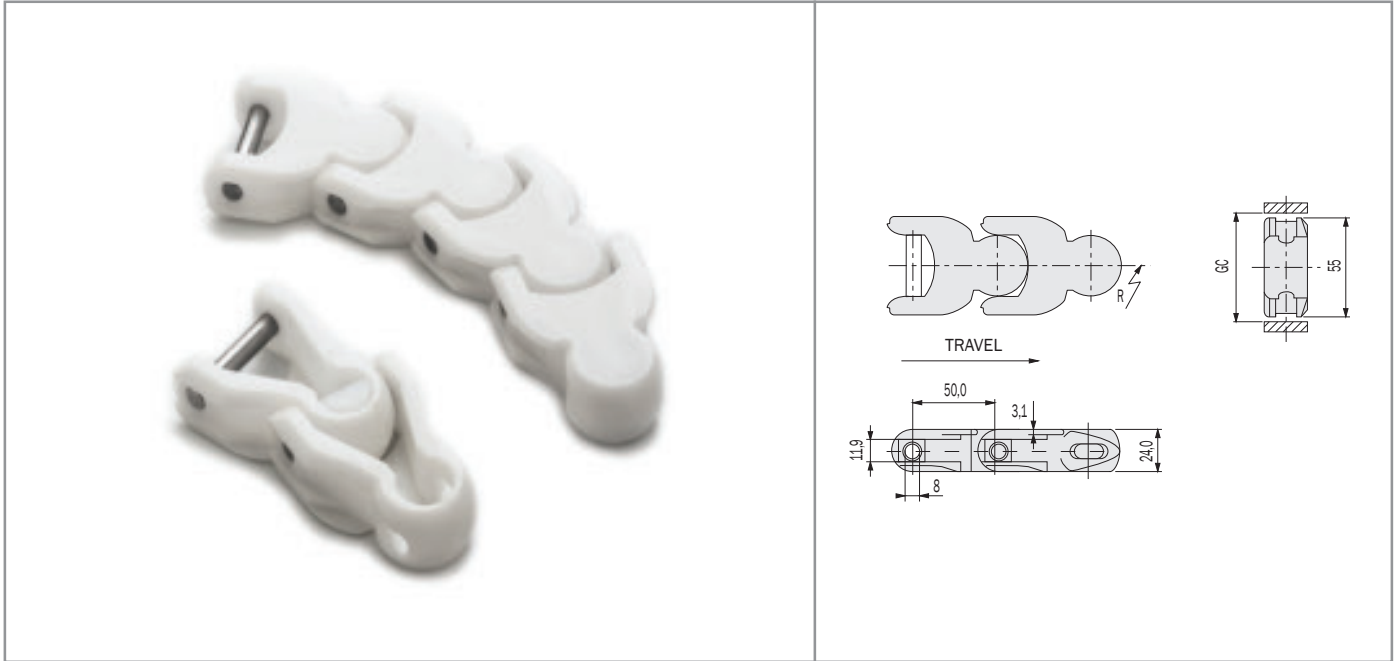

WLF 1500 - LOW FRICTION ACETAL RESIN

- Plates in self-lubricating, low friction acetal resin, white-coloured.
- Pins in austenitic chrome-nickel stainless steel, work hardened for high resistance.



p.195
p.213



p.227



p.231

PRODUCT CODE		INTERNAL CODE		CHARACTERISTICS		
		Radius R (mm)	GC st. (mm)	GC sid. (mm)	Working Load Max N (21°C)	Weight kg/m
WLF 1500	1500.WA	150	58	58	4000	1.37

- Standard shipping lengths = 122 pitches = 20 feet = 6,10 metres.

biplanar thermoplastic chains

1700 / 1700 TAB SERIES

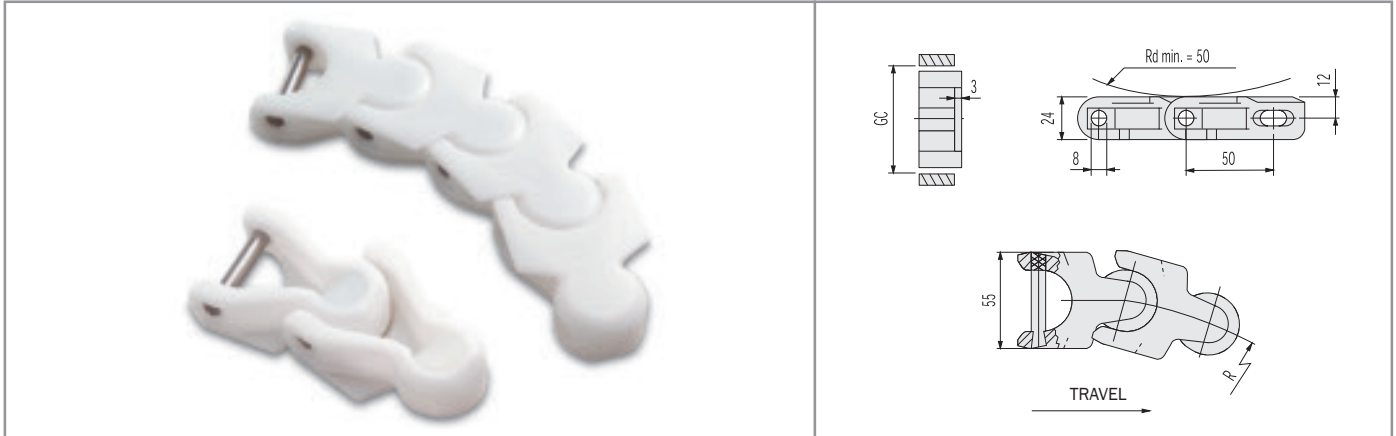

1700 - LOW FRICTION ACETAL RESIN

- Plates in self-lubricating low friction acetal resin
- Pins in austenitic chrome-nickel stainless steel, work hardened for high resistance.

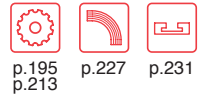

PRODUCT CODE	INTERNAL CODE	CHARACTERISTICS				
	WHITE COLOUR	Radius R (mm)	GC st. (mm)	GC sid. (mm)	Working Load Max N (21°C)	Weight kg/m
WLF 1700	1700.WA	140	58	58	4000	1.26
	LIGHT BROWN COLOUR					
LFA 1700	1700.LFA	140	58	58	4000	1.26

- Standard shipping lengths = 122 pitches = 20 feet = 6,10 metres.

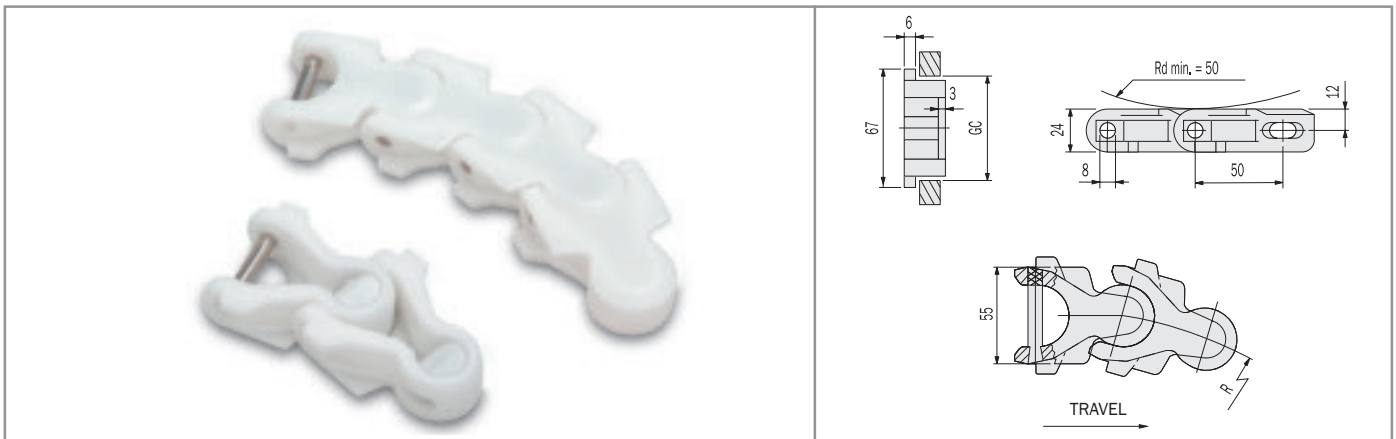

1700 TAB - LOW FRICTION ACETAL RESIN

- Plates in self-lubricating low friction acetal resin
- Pins in austenitic chrome-nickel stainless steel, work hardened for high resistance.

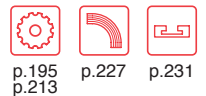

PRODUCT CODE	INTERNAL CODE	CHARACTERISTICS				
	WHITE COLOUR	Radius R (mm)	GC st. (mm)	GC sid. (mm)	Working Load Max N (21°C)	Weight kg/m
WLF 1700 TAB	1700TAB.WA	140	58	58	4000	1.30
	LIGHT BROWN COLOUR					
LFA 1700 TAB	1700TAB.LFA	140	58	58	4000	1.30

- Standard shipping lengths = 122 pitches = 20 feet = 6,10 metres.

biplanar thermoplastic chains

1701 / 1701 TAB SERIES

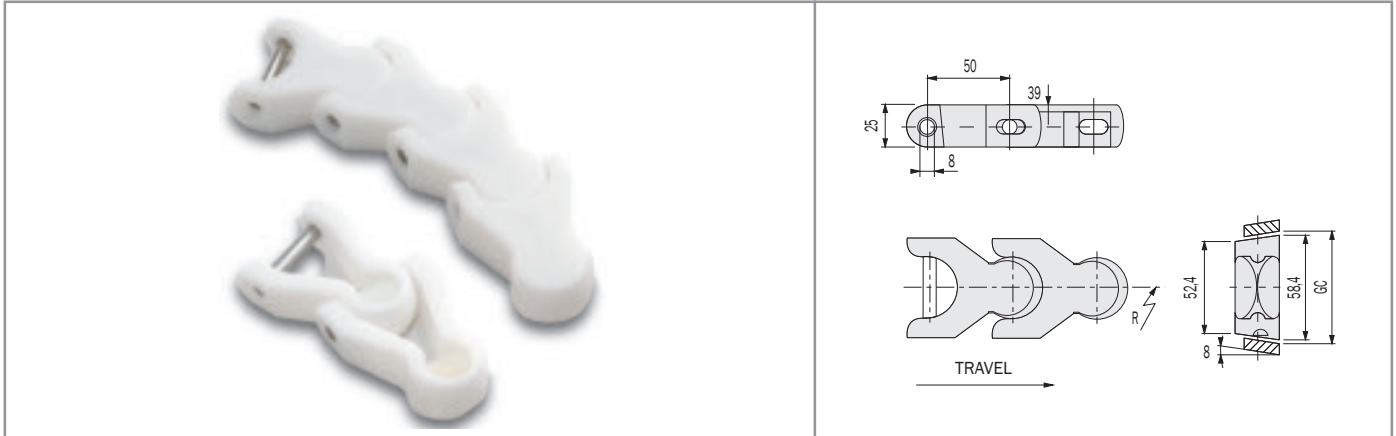

WLF 1701 - LOW FRICTION ACETAL RESIN

- Plates in self-lubricating low friction acetal resin, white coloured.
- Pins in austenitic chrome-nickel stainless steel, work hardened for high resistance.



PRODUCT CODE	INTERNAL CODE	CHARACTERISTICS				
		Radius R (mm)	GC st. (mm)	GC sid. (mm)	Working Load Max N (21°C)	Weight kg/m
WLF 1701	1701.WA	150	62	60.3	4000	1.50

- Standard shipping lengths = 122 pitches = 20 feet = 6,10 metres.

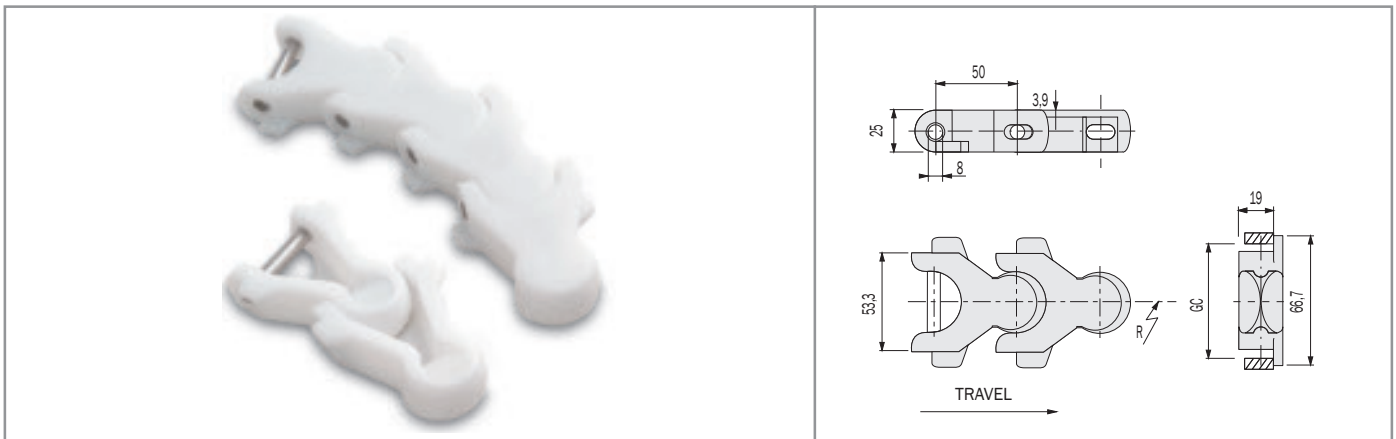

WLF 1701 TAB - LOW FRICTION ACETAL RESIN

- Plates in self-lubricating low friction acetal resin, white coloured.
- Pins in austenitic chrome-nickel stainless steel, work hardened for high resistance.

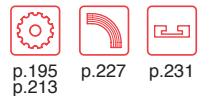

PRODUCT CODE	INTERNAL CODE	CHARACTERISTICS				
		Radius R (mm)	GC st. (mm)	GC sid. (mm)	Working Load Max N (21°C)	Weight kg/m
WLF 1701 TAB	1701.TAB.WA	150	57.5	56.0	4000	1.50

* If R > 500, GC = 55

- Standard shipping lengths = 122 pitches = 20 feet = 6,10 metres.

biplanar thermoplastic chains

1702 / 1703 SERIES

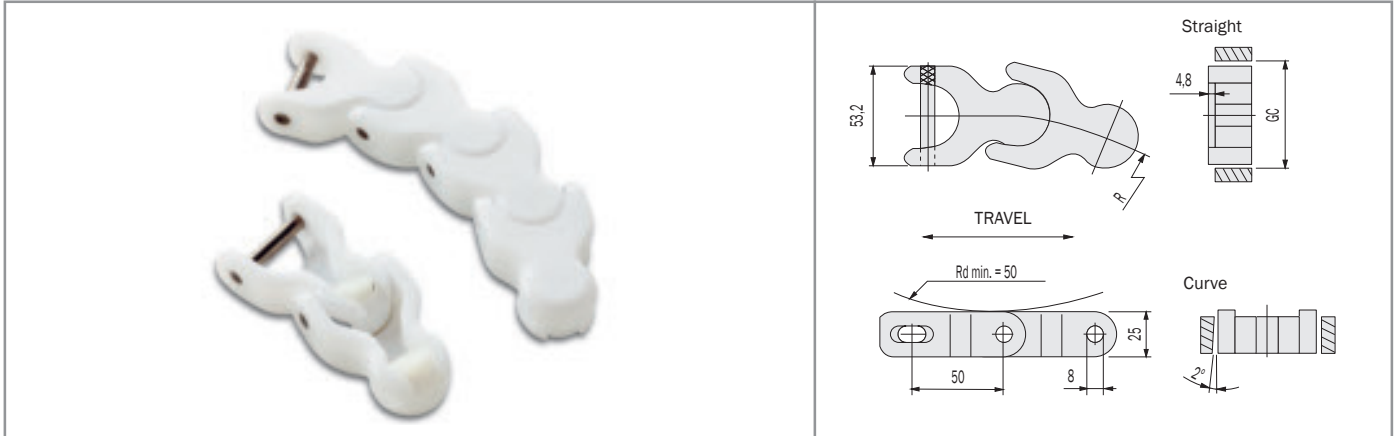

WLF 1702 - LOW FRICTION ACETAL RESIN

- Plates in self-lubricating low friction acetal resin, white coloured.
- Pins in austenitic chrome-nickel stainless steel, work hardened for high resistance.



PRODUCT CODE	INTERNAL CODE	CHARACTERISTICS				
		Radius R (mm)	GC st. (mm)	GC sid. (mm)	Working Load Max N (21°C)	Weight kg/m
WLF 1702	1702.WA	140	59.5	56.8	4000	1.43

- Standard shipping lengths = 122 pitches = 20 feet = 6,10 metres.

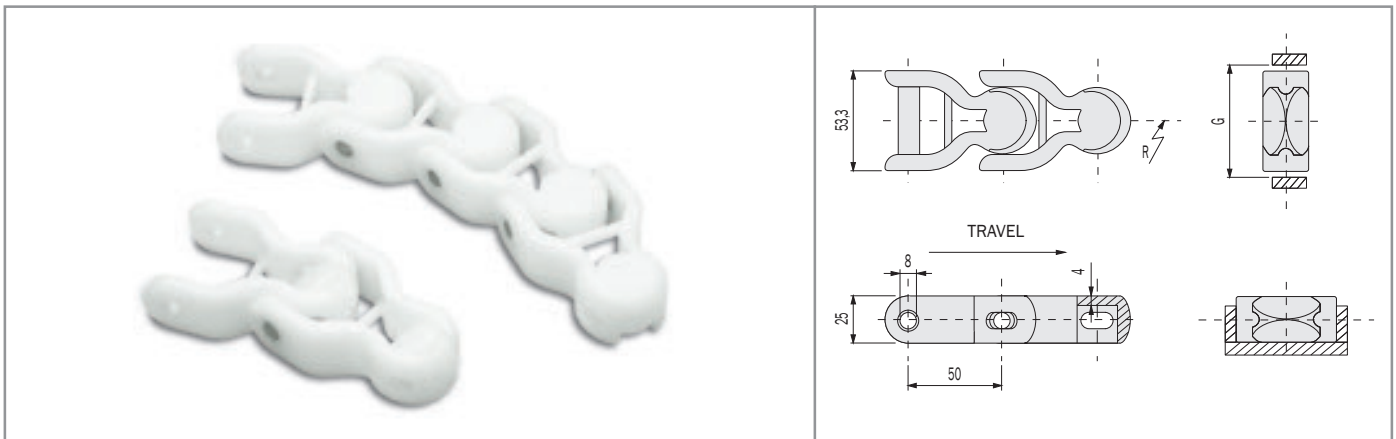

WLF 1703 - LOW FRICTION ACETAL RESIN

- Plates in self-lubricating low friction acetal resin, white coloured.
- The open design ensures optimum cleaning possibilities.
- Pins in austenitic chrome-nickel stainless steel, work hardened for high resistance.



PRODUCT CODE	INTERNAL CODE	CHARACTERISTICS				
		Radius R (mm)	GC st. (mm)	GC sid. (mm)	Working Load Max N (21°C)	Weight kg/m
WLF 1703	1703.WA	150	58.7	56.9	4000	1.43

- Standard shipping lengths = 122 pitches = 20 feet = 6,10 metres.

biplanar thermoplastic chains accessories

CHAIN PEGS



AVAILABLE FOR - 1500, 1700, 1700 TAB,
1701, 1701 TAB, 1702, 1703 SERIES

• Pegs in self-lubricating low friction acetal resin or Polypropylene, white coloured.

PRODUCT CODE	INTERNAL CODE
Code biplanar thermoplastic chains + M	Ex: 1702.WA.M

- When ordering, please state the required distance between the pegs.